

DVP-SA2

Instruction Sheet
Bilgi Dökümanı

安 裝 說 明
安 裝 說 明

Programmable Logic Controller
Programlanabilir Lojik Kontrolör
可程式控制器
可編程控制器

2014-04-30

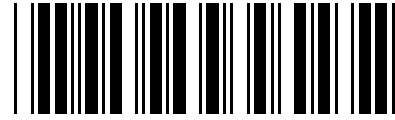

5012604904-SSA4



Thank you for choosing Delta DVP-SA2. DVP-SA2 is a 12-point (8DI + 4DO) PLC MPU, offering various instructions and with 16k steps program memory, able to connect to all DVP-S series extension modules and high-speed extension modules, including digital I/O (max. 480 I/O points) and analog modules (for A/D, D/A conversion and temperature measurement). 2 points of 100 kHz and 2 points of 10 kHz high-speed pulse output satisfy all kinds of applications. DVP-SA2 is small in size and easy to install. Users do not have to install any batteries in DVP-SA2 series PLCs. The PLC programs and the latched data are stored in the high-speed flash memories.

EN ✘ DVP-SA2 is an OPEN-TYPE device. It should be installed in a control cabinet free of airborne dust, humidity, electric shock and vibration. To prevent non-maintenance staff from operating DVP-SA2, or to prevent an accident from damaging DVP-SA2, the control cabinet in which DVP-SA2 is installed should be equipped with a safeguard. For example, the control cabinet in which DVP-SA2 is installed can be unlocked with a special tool or key.

EN ✘ DO NOT connect AC power to any of I/O terminals, otherwise serious damage may occur. Please check all wiring again before DVP-SA2 is powered up. After DVP-SA2 is disconnected, Do NOT touch any terminals in a minute. Make sure that the ground terminal ⊕ on DVP-SA2 is correctly grounded in order to prevent electromagnetic interference.

FR ✘ DVP-SA2 est un module OUVERT. Il doit être installé que dans une enceinte protectrice (boîtier, armoire, etc.) saine, dépourvue de poussière, d'humidité, de vibrations et hors d'atteinte des chocs électriques. La protection doit éviter que les personnes non habilitées à la maintenance puissent accéder à l'appareil (par exemple, une clé ou un outil doivent être nécessaire pour ouvrir a protection).

FR ✘ Ne pas appliquer la tension secteur sur les bornes d'entrées/Sorties, ou l'appareil DVP-SA2 pourra être endommagé. Merci de vérifier encore une fois le câblage avant la mise sous tension du DVP-SA2. Lors de la déconnection de l'appareil, ne pas toucher les connecteurs dans la minute suivante. Vérifier que la terre est bien reliée au connecteur de terre ⊕ afin d'éviter toute interférence électromagnétique.

■ Product Profiles

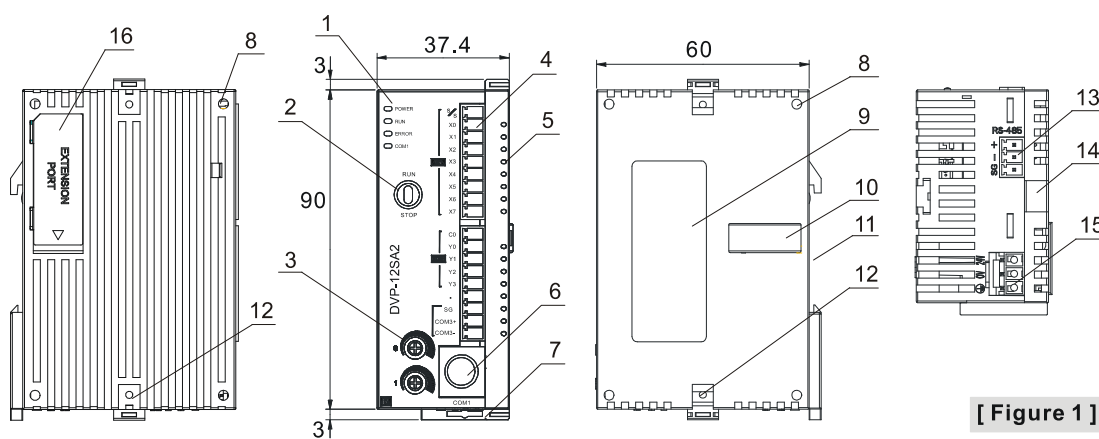

Unit: mm

1. POWER, RUN, ERROR, COM1 indicator	9. Nameplate
2. RUN/STOP switch	10. Right-side extension port
3. VR0/VR1	11. DIN rail mounting slot (35mm)
4. I/O terminals and COM3 comm. port (RS-485)	12. Extension unit clip
5. I/O point and COM2, COM3 indicator	13. COM2 communication port (RS-485)
6. COM1 communication port (RS-232)	14. Mounting rail for extension module
7. DIN rail clip	15. DC power input
8. Mounting hole for extension module	16. Left-side module connection port

■ Electrical Specifications

Item \ Model	DVP12SA211R	DVP12SA211T
Power supply voltage	24 VDC (-15 to 20%) (with counter-connection protection on the polarity of DC input power) DVPPS01/PS02: input 100 to 240 VAC, output 24 VDC/1A (PS02: 2A)	
Connector	European standard removable terminal block (Pin pitch: 3.5mm)	
Operation	Maximum power loss time is 10ms or less.	
Inrush current	Max. 7.5 A@24 VDC, $I^2t = 0.25 A^2S$	
Fuse capacity	2.5 A/30 VDC, Polyswitch	
Power consumption	1.8 W	1.5 W
Power protection	With counter-connection protection on the polarity of DC input power	
Insulation resistance	> 5 MΩ (all I/O point-to-ground: 500 VDC)	
Noise immunity	ESD (IEC 61131-2, IEC 61000-4-2): 8kV Air Discharge EFT (IEC 61131-2, IEC 61000-4-4): Power Line: 2kV, Digital I/O: 1kV, Analog & Communication I/O: 1kV RS (IEC 61131-2, IEC 61000-4-3): 26MHz ~ 1GHz, 10V/m	
Grounding	The diameter of grounding wire cannot be smaller than the wire diameter of terminals L and N (All DVP units should be grounded directly to the ground pole).	
Operation / storage	Operation: 0 to 55°C (temp.), 50 to 95% (humidity), Pollution degree 2 Storage: -25 to 70°C (temp.), 5 to 95% (humidity)	
Vibration / shock resistance	International standards: IEC61131-2, IEC 68-2-6 (TEST Fc)/IEC61131-2 & IEC 68-2-27 (TEST Ea)	
Weight (g)	140g	131g

Spec. \ Items		Input Points	
		24 VDC (-15 to 20%) single common port input	
Input No.		X0 to X2	X3 to X7
Input type		DC (SINK or SOURCE)	
Input current ($\pm 10\%$)		24 VDC, 5 mA	
Input impedance		4.7 kΩ	
Max. frequency		100 kHz	10 kHz
Action level	Off → On	> 15 VDC	
	On → Off	< 5 VDC	
Response time	Off → On	< 2.5 μs	< 20 μs
	On → Off	< 5 μs	< 50 μs
Filter time		Adjustable within 0 ~ 20ms by D1020 (Default: 10ms)	

Spec. \ Items		Output Points		
		Relay	Transistor	
Output No.		Y0 to Y3	Y0, Y2	Y1, Y3
Max. frequency		1 Hz	100 kHz	10 kHz
Working voltage		250 VAC, < 30 VDC	5 to 30 VDC ^{#1}	
Max. load	Resistive	1.5 A/1 point (5 A/COM)	0.5 A/1 point (2 A/COM)	
	Inductive	^{#2}	15 W (30 VDC)	
	Lamp	20 WDC/100 WAC	2.5 W (30 VDC)	
Response time	Off → On	Approx. 10 ms	2 μs ^{#3}	20 μs ^{#3}
	On → Off		3 μs ^{#3}	30 μs ^{#3}

#1: UP, ZP must work with external auxiliary power supply 24 VDC (-15 to +20%), rated consumption approx. 1mA/point.

#2: Life curves

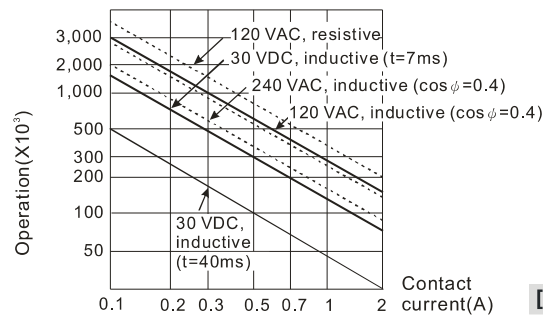

[Figure 2]

#3: Load = 0.5A

■ I/O Configuration

Model	Input		Output		I/O Configuration	
	Point	Type	Point	Type	Relay	Transistor
DVP 12SA211R	8	DC (Sink Or Source)	4	Relay	S/S X0 X1 X2 X3 X4 X5 X6 X7	S/S X0 X1 X2 X3 X4 X5 X6 X7
DVP 12SA211T				Transistor	C0 Y0 Y1 Y2 Y3 ● SG COM3+ COM3-	Y0 Y1 Y2 Y3 UP ZP SG COM3+ COM3-

Note: The layout of output terminals on DVP-SA2 is different from that on DVP-SA.

■ Dimension & Installation

Please install the PLC in an enclosure with sufficient space around it to allow heat dissipation, See [Figure 3].

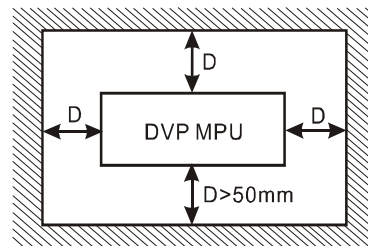

[Figure 3]

- **Direct Mounting:** Use M4 screw according to the dimension of the product.
- **DIN Rail Mounting:** When mounting the PLC to 35mm DIN rail, be sure to use the retaining clip to stop any side-to-side movement of the PLC and reduce the chance of wires being loose. The retaining clip is at the bottom of the PLC. To secure the PLC to DIN rail, pull down the clip, place it onto the rail and gently push it up. To remove the PLC, pull the retaining clip down with a flat screwdriver and gently remove the PLC from DIN rail.

■ Wiring

1. Use 22-16AWG (1.5mm) single or multiple core wire on I/O wiring terminals. See the figure in the right hand side for its specification. PLC terminal screws should be tightened to 1.90 kg-cm (1.65 in-lbs) and please use only 60/75°C copper conductor.

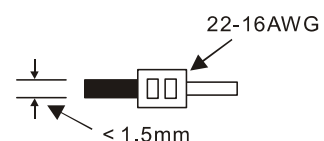

2. DO NOT wire empty terminal. DO NOT place the I/O signal cable in the same wiring circuit.

- DO NOT drop tiny metallic conductor into the PLC while screwing and wiring. Tear off the sticker on the heat dissipation hole for preventing alien substances from dropping in to ensure normal heat dissipation of the PLC.

◆ Power Supply

The power input of DVP-SA2 is DC. When operating DVP-SA2, please note the following points:

- The power is connected to two terminals, 24 VDC and 0 V, and the range of power is 20.4 to 28.8 VDC. If the power voltage is less than 17.5 VDC, the PLC will stop running, all outputs will go “Off”, and the ERROR indicator will start to blink continuously.
- The power shutdown for less than 10ms will not affect the operation of the PLC. However, the shutdown time that is too long or the drop of power voltage will stop the operation of the PLC, and all outputs will go off. When the power returns to normal status, the PLC will automatically resume the operation. (Please take care of the latched auxiliary relays and registers inside the PLC when doing the programming).

◆ Safety Wiring

Since DVP-SA2 is only compatible with DC power supply, Delta’s power supply modules (DVPPS01/DVPPS02) are the suitable power supplies for DVP-SA2. We suggest you install the protection circuit at the power supply terminal to protect DVPPS01 or DVPPS02. See the figure below.

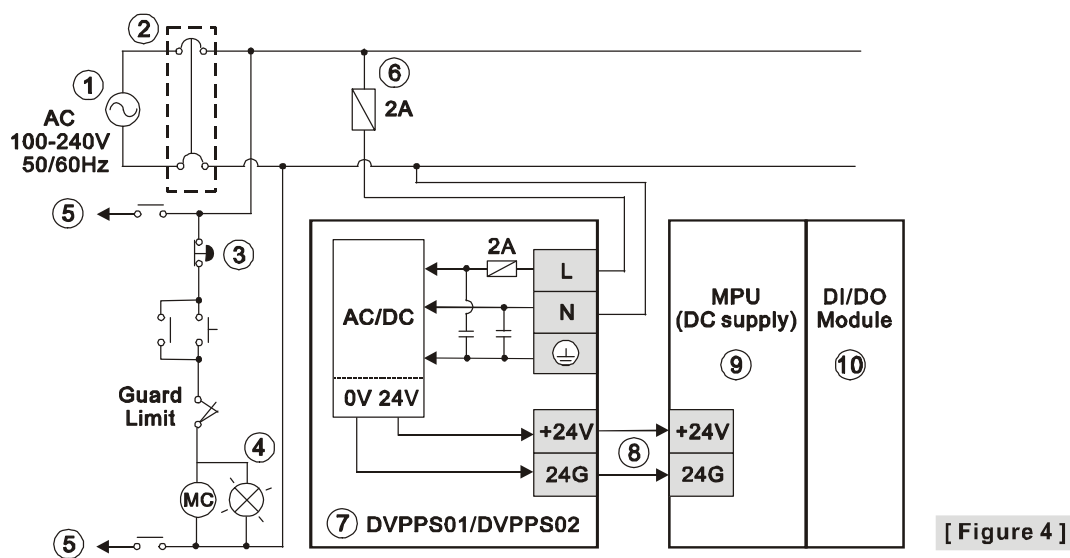

① AC power supply: 100 ~ 240VAC, 50/60Hz	② Breaker
③ Emergency stop: This button cuts off the system power supply when accidental emergency takes place.	
④ Power indicator	⑤ AC power supply load
⑥ Power supply circuit protection fuse (2A)	⑦ DVPPS01/DVPPS02
⑧ DC power supply output: 24 VDC, 500 mA	⑨ DVP-PLC (main processing unit)
⑩ Digital I/O module	

◆ Input Point Wiring

There are 2 types of DC inputs, SINK and SOURCE. (See the example below. For detailed point configuration, please refer to the specification of each model.)

• **DC Signal IN – SINK mode**
Input point loop equivalent circuit

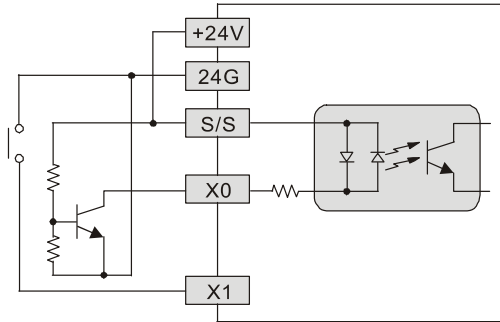

[Figure 5]

• **DC Signal IN – SOURCE mode**
Input point loop equivalent circuit

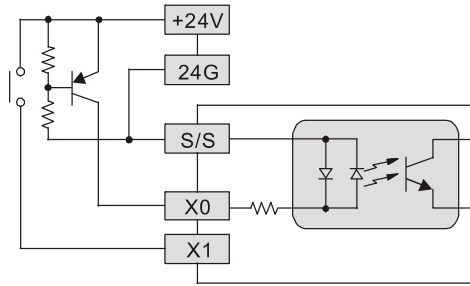

[Figure 6]

◆ **Output Point Wiring**

1. DVP-SA2 has two output modules on it, relay and transistor. Be aware of the connection of shared terminals when wiring output terminals.
2. Relay output terminals, Y0 to Y3 of relay models use C0 common port. See [Figure 7]. When the output points are enabled, their corresponding indicators on the front panel will be on.
3. Transistor output terminals, Y0 to Y3 of transistor (NPN) models use UP, ZP common port. See [Figure 8].

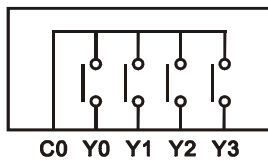

[Figure 7]

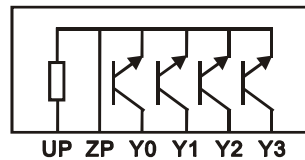

[Figure 8]

4. Isolation circuit: The optical coupler is used to isolate signals between the circuit inside PLC and input modules.

• **Relay (R) output circuit wiring**

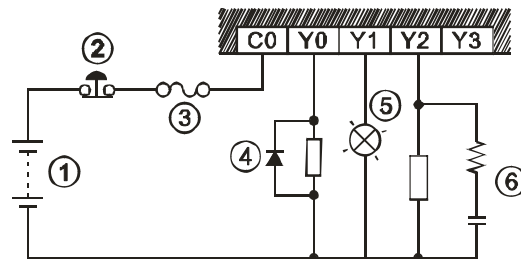

[Figure 9]

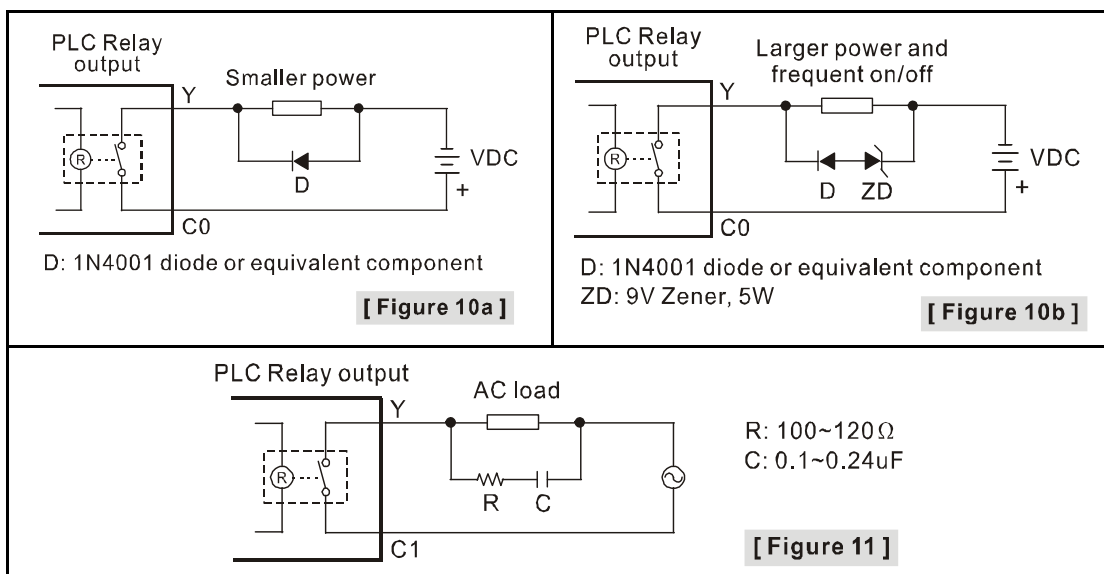

① DC power supply

② Emergency stop: Uses external switch

- ③ Fuse: 5 to 10A fuse at the shared terminal of output contacts to protect the output circuit
- ④ Transient voltage suppressor (SB360 3A 60V): Extends the life span of contact.
 - 1. Diode suppression of DC load: Used when in smaller power [Figure 10a]
 - 2. Diode + Zener suppression of DC load: Used when in larger power and frequent On/Off [Figure 10b]
- ⑤ Incandescent light (resistive load)
- ⑥ Absorber: Reduces the interference on AC load [Figure 11]

• **Transistor (T) output circuit wiring**

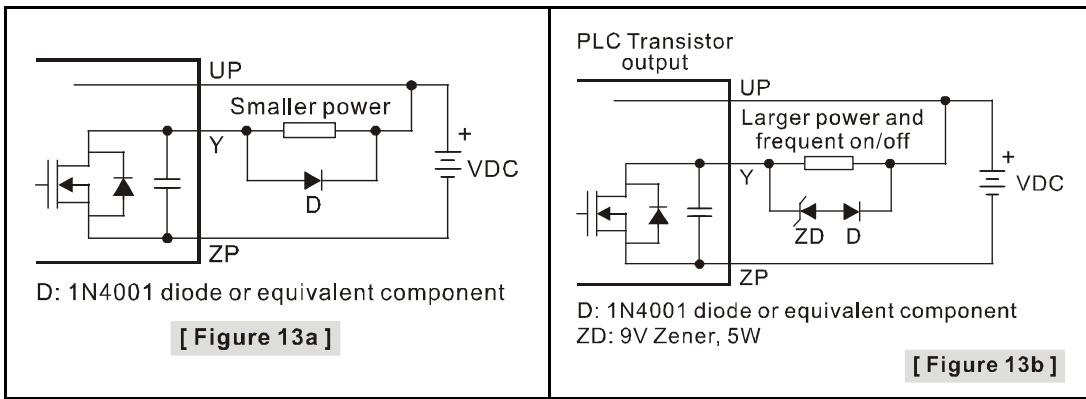
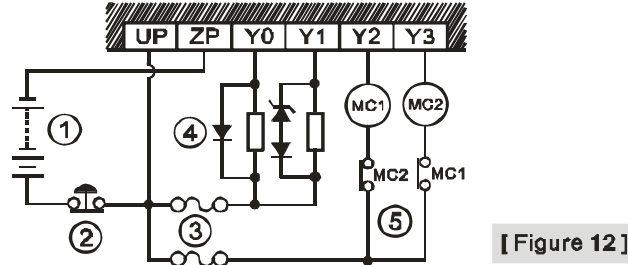

- ① DC power supply ② Emergency stop ③ Circuit protection fuse
- ④ The output of the transistor model is “open collector”. If Y0/Y1 is set to pulse output, the output current has to be bigger than 0.1 A to ensure normal operation of the model.
 - 1. Diode suppression: Used when in smaller power [Figure 13a]
 - 2. Diode + Zener suppression: Used when in larger power and frequent On/Off [Figure 13b]
- ⑤ Manually exclusive output: For example, Y2 and Y3 control the forward running and reverse running of the motor, forming an interlock for the external circuit, together with the PLC internal program, to ensure safe protection in case of any unexpected errors.

◆ **RS-485 Wiring**

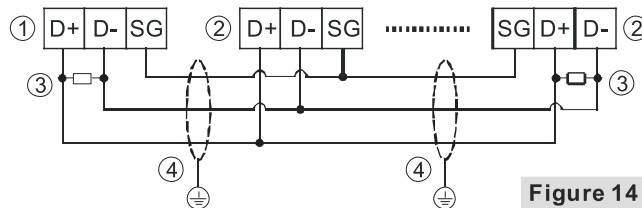

- ① Master node ② Slave node
- ③ Terminal resistor ④ Shielded cable

Note:

1. Terminal resistors are suggested to be connected to master and the last slave with resistor value of 120Ω.
2. To ensure communication quality, please apply double shielded twisted pair cable (20AWG) for wiring.

■ **Precision of the RTC (Second/Month)**

Temperature (°C/°F)	0/32	25/77	55/131
Maximum error (Second)	-117	52	-132

Duration in which the RTC is latched: One week